

Dosing Valve

313342D

EN

For use with XM and Xtreme Mix™ plural-component sprayers. For professional use only.

Part No. 255478, Series B

XM Sprayer Dosing Valve Assembly

Maximum working pressure 7250 psi (50 MPa, 500 bar)

Part No. 245846, Series A

Xtreme Mix™ Sprayer Dosing Valve Assembly

Maximum working pressure 7250 psi (50 MPa, 500 bar)



Important Safety Instructions

Read all warnings and instructions in this manual.
Save these instructions.

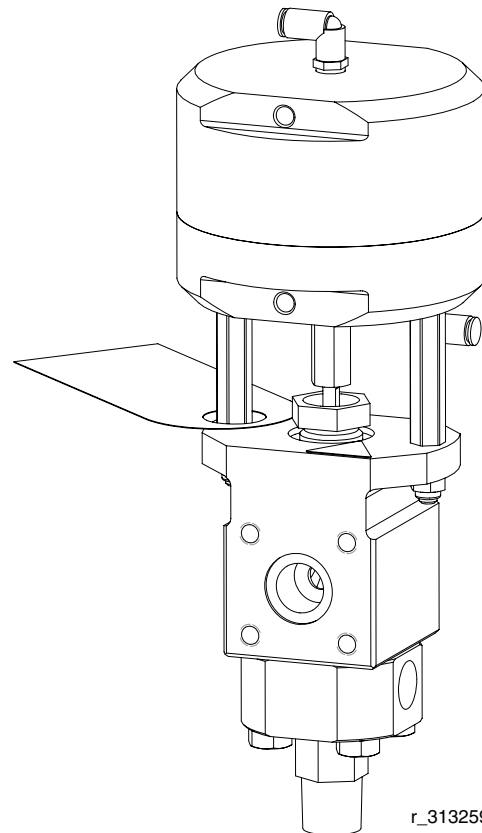

r_313259_313342_1

Contents

| | |
|--------------------------------------|-----------|
| Related Manuals | 2 |
| Warnings | 3 |
| Setup | 5 |
| Repair | 6 |
| Disassemble Fluid Section | 6 |
| Parts | 8 |
| Technical Data | 11 |
| Dimensions | 11 |
| Graco Standard Warranty | 12 |
| Graco Information | 12 |

Related Manuals





Manuals are available at www.graco.com.

Component Manuals in U.S. English:





| Manual | Description |
|--------|---|
| 312359 | XM Operation |
| 313289 | XM Repair |
| 313292 | XM OEM, Instructions-Parts |
| 313343 | High Flow Severe Duty Shutoff Check Valve, Instructions-Parts |

Warnings

The following warnings are for the setup, use, grounding, maintenance, and repair of this equipment. The exclamation point symbol alerts you to a general warning and the hazard symbol refers to procedure-specific risk. Refer back to these warnings. Additional, product-specific warnings may be found throughout the body of this manual where applicable.

|  WARNING | |
|--|---|
|  | <p>FIRE AND EXPLOSION HAZARD</p> <p>Flammable fumes, such as solvent and paint fumes, in work area can ignite or explode. To help prevent fire and explosion:</p> <ul style="list-style-type: none"> • Use equipment only in well ventilated area. • Eliminate all ignition sources; such as pilot lights, cigarettes, portable electric lamps, and plastic drop cloths (potential static arc). • Keep work area free of debris, including solvent, rags and gasoline. • Do not plug or unplug power cords, or turn power or light switches on or off when flammable fumes are present. • Ground all equipment in the work area. See Grounding instructions. • Use only grounded hoses. • Hold gun firmly to side of grounded pail when triggering into pail. • If there is static sparking or you feel a shock, stop operation immediately. Do not use equipment until you identify and correct the problem. • Keep a working fire extinguisher in the work area. |
|  | <p>EQUIPMENT MISUSE HAZARD</p> <p>Misuse can cause death or serious injury.</p> <ul style="list-style-type: none"> • Do not operate the unit when fatigued or under the influence of drugs or alcohol. • Do not exceed the maximum working pressure or temperature rating of the lowest rated system component. See Technical Data in all equipment manuals. • Use fluids and solvents that are compatible with equipment wetted parts. See Technical Data in all equipment manuals. Read fluid and solvent manufacturer's warnings. For complete information about your material, request MSDS forms from distributor or retailer. • Check equipment daily. Repair or replace worn or damaged parts immediately with genuine manufacturer's replacement parts only. • Do not alter or modify equipment. • Use equipment only for its intended purpose. Call your distributor for information. • Route hoses and cables away from traffic areas, sharp edges, moving parts, and hot surfaces. • Do not kink or over bend hoses or use hoses to pull equipment. • Keep children and animals away from work area. • Comply with all applicable safety regulations. |
|  | <p>PRESSURIZED EQUIPMENT HAZARD</p> <p>Fluid from the gun/dispense valve, leaks, or ruptured components can splash in the eyes or on skin and cause serious injury.</p> <ul style="list-style-type: none"> • Follow Pressure Relief Procedure in this manual, when you stop spraying and before cleaning, checking, or servicing equipment. • Tighten all fluid connections before operating the equipment. • Check hoses, tubes, and couplings daily. Replace worn or damaged parts immediately. |

! WARNING

| | |
|---|--|
|  | <p>MOVING PARTS HAZARD</p> <p>Moving parts can pinch or amputate fingers and other body parts.</p> <ul style="list-style-type: none"> • Keep clear of moving parts. • Do not operate equipment with protective guards or covers removed. • Pressurized equipment can start without warning. Before checking, moving, or servicing equipment, follow the Pressure Relief Procedure in this manual. Disconnect power or air supply. |
|  | <p>TOXIC FLUID OR FUMES HAZARD</p> <p>Toxic fluids or fumes can cause serious injury or death if splashed in the eyes or on skin, inhaled, or swallowed.</p> <ul style="list-style-type: none"> • Read MSDS's to know the specific hazards of the fluids you are using. • Store hazardous fluid in approved containers, and dispose of it according to applicable guidelines. • Always wear impervious gloves when spraying or cleaning equipment. |
|  | <p>BURN HAZARD</p> <p>Equipment surfaces and fluid that's heated can become very hot during operation. To avoid severe burns, do not touch hot fluid or equipment. Wait until equipment/fluid has cooled completely.</p> |
|  | <p>PERSONAL PROTECTIVE EQUIPMENT</p> <p>You must wear appropriate protective equipment when operating, servicing, or when in the operating area of the equipment to help protect you from serious injury, including eye injury, inhalation of toxic fumes, burns, and hearing loss. This equipment includes but is not limited to:</p> <ul style="list-style-type: none"> • Protective eyewear • Clothing and respirator as recommended by the fluid and solvent manufacturer • Gloves • Hearing protection |

Setup

Follow the instructions below to setup dosing valve 255478 on a XM plural-component sprayer as the hardener and resin dosing valves.

NOTE:

Dosing valve 245846 was used on the old Xtreme Mix™ and should not be installed on XM sprayers.

1. Remove plug (31) if 255478 will be used on a machine with pressure transducers (P).

NOTE:

Valves are shipped with the parts orientated as a hardener valve.

2. *Resin dosing valve (left side):* Remove screws (27) and turn seat housing (26) 90° so that the side ports are facing to the left for the sampling valve (S) and to the rear for the temperature sensor (not shown). See FIG. 1.
3. *Hardener dosing valve (right side):* If necessary, remove screws (27) turn seat housing (26) 90° so

that the side ports are facing to the right and rear for the sampling valve (S) and temperature sensor (T).

4. Transfer all valves, fittings, and sensors from the dosing valve being removed from the machine to the new valve.
5. Use new o-ring (36) when replacing recirculation valve (R). If not using valve (R), plug port with plug (33). See parts illustration on page 8.
6. If not using sampling valve (S), plug port with plug (29).
7. Replace seat housing (26) with screws (27).
8. Fill dosing valves A and B packing nuts (7) with throat seal liquid (TSL) and tighten 1/4 turn after nut contacts packings; about 145-155 in.-lbs (16-18 N•m).
9. See XM plural-component sprayer repair manual 313289 for installation instructions.

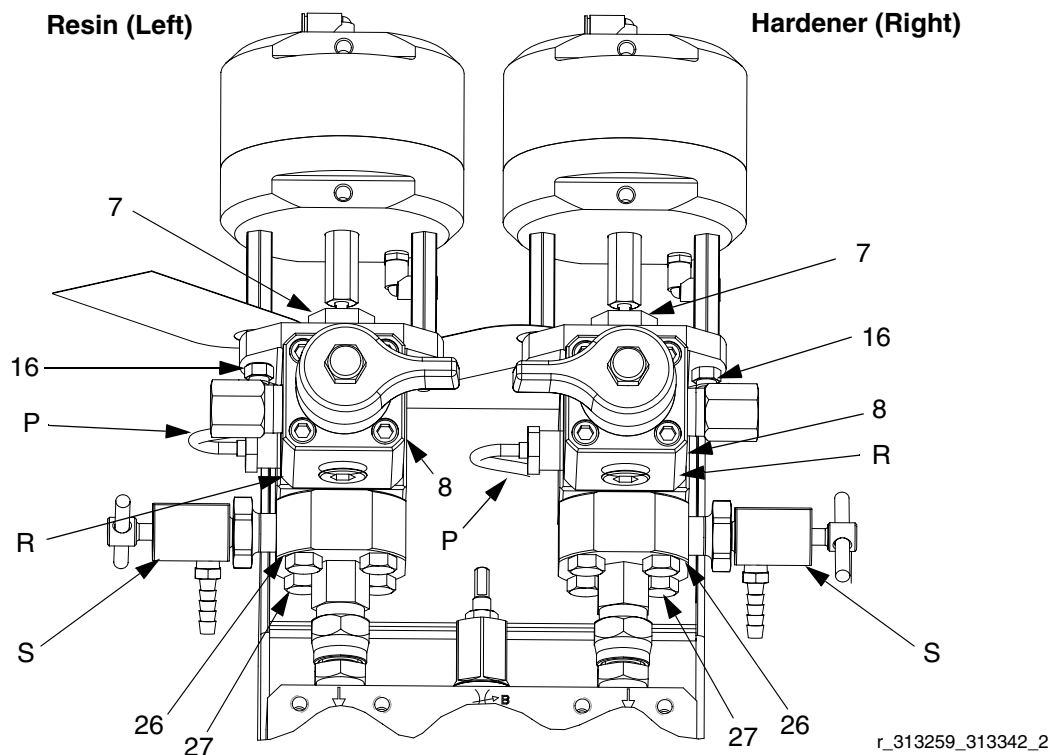

FIG. 1: Hardener and Resin Dosing Valve 255478 Orientation

Repair



Reference parts illustration on page 8.

Disassemble Fluid Section

1. Remove dosing valve from sprayer system. See system repair manual for instructions.
2. Mount the valve upside down in a vice holding the upper flats of housing (8).
3. Remove screws (27) and seat housing (26). Remove seat (24), and o-rings (25) from housing (8).
4. Remove housing (8) from vice and clamp upper flats of air cylinder (2) in vice.
5. Unscrew packing nut (7) and remove locknuts (16). Pull fluid housing (8) straight up off of needle assembly (10) and packing stack (17, 18, 19).
6. Unscrew needle (10) from piston rod (5).
7. Remove packings (17, 18, 19). Inspect needle (10) and replace if worn.

Replace air cylinder seals:

1. Unscrew cylinder (4) from cap (2).

NOTE:

For 255478 only: A phillips screwdriver can be used as a handle in the holes on the flats to unscrew cap (2).

2. Unscrew locknut (11).
3. Remove piston (3) and replace o-rings (12, 13, 14, and 23).
4. Clean all parts and lubricate seals with lithium grease.
5. Reassemble using illustration and notes on page 8 and 9.
6. Use loose o-ring (36) when re-mounting your circulation valve to the front of the dosing valve 255478.

Parts

255478, Dosing Valve for XM Plural-Component Sprayers

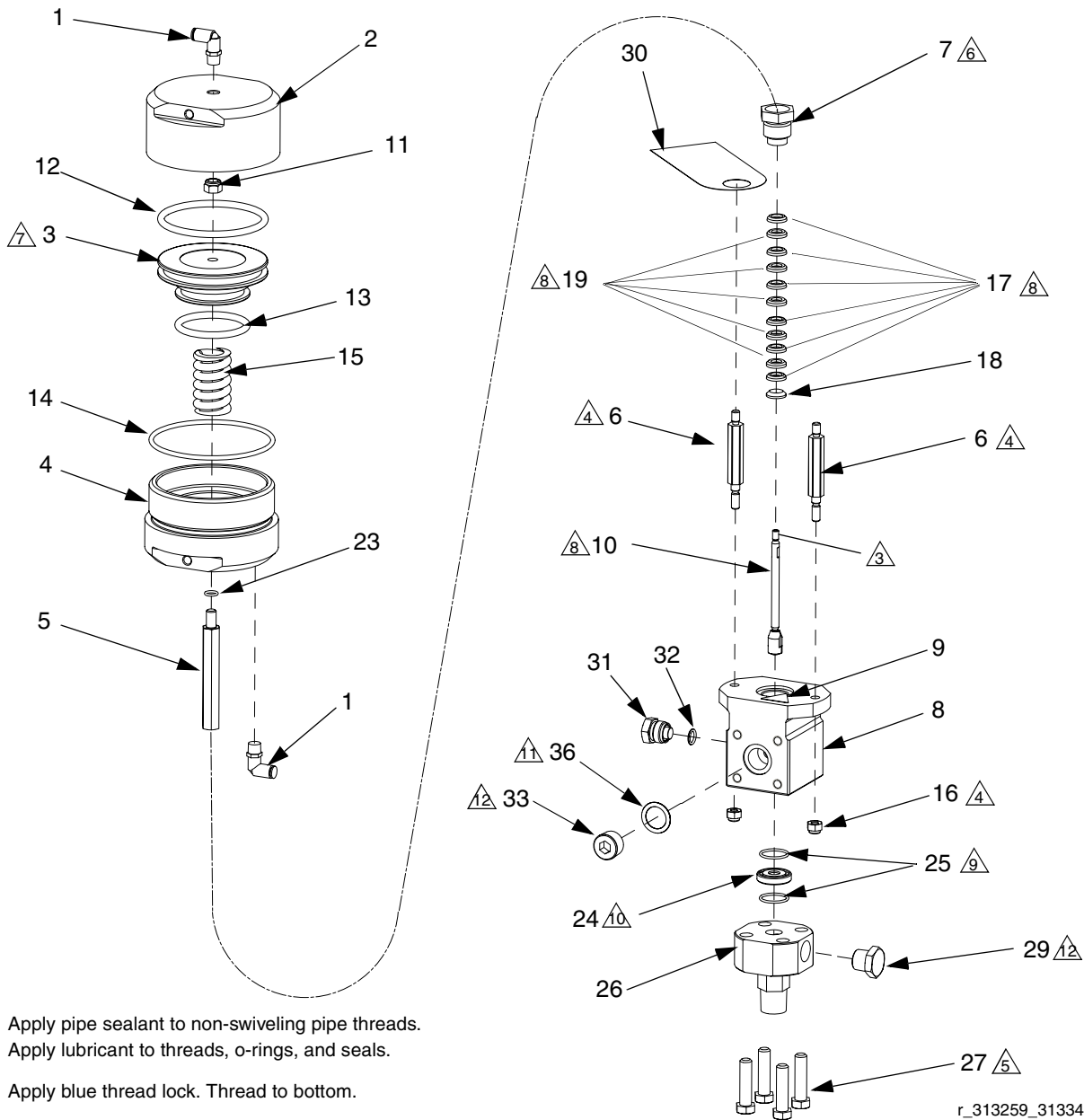

1. Apply pipe sealant to non-swiveling pipe threads.
2. Apply lubricant to threads, o-rings, and seals.
3. Apply blue thread lock. Thread to bottom.
4. Torque to 5-7 ft-lbs (7-9 N•m).
5. Torque to 30-40 ft-lbs (41-54 N•m).
6. Tighten packing nut 1/4 turn after nut bottoms out; 145-155 in./lbs (16-18 N•m). Check packing nut tightness about once a month. Keep packing nut filled with TSL.
7. Lubricate and press piston evenly into cylinder.
8. Clean ball housing (10) and packing cavity before reinstalling packings (17, 18, 19). Lubricate packings and install with lips facing down away from packing nut (7) in order shown.

9. Replace o-rings (25) when seat housing (26) is removed.
10. Inspect reversible seat for damage. If one side is worn, reverse seat.
11. Use o-ring (36) if replacing circulation valve 255278.
12. Use if recirculation valve is not used.

r_313259_313342_3

245846, Xtreme Mix™ Dosing Valve

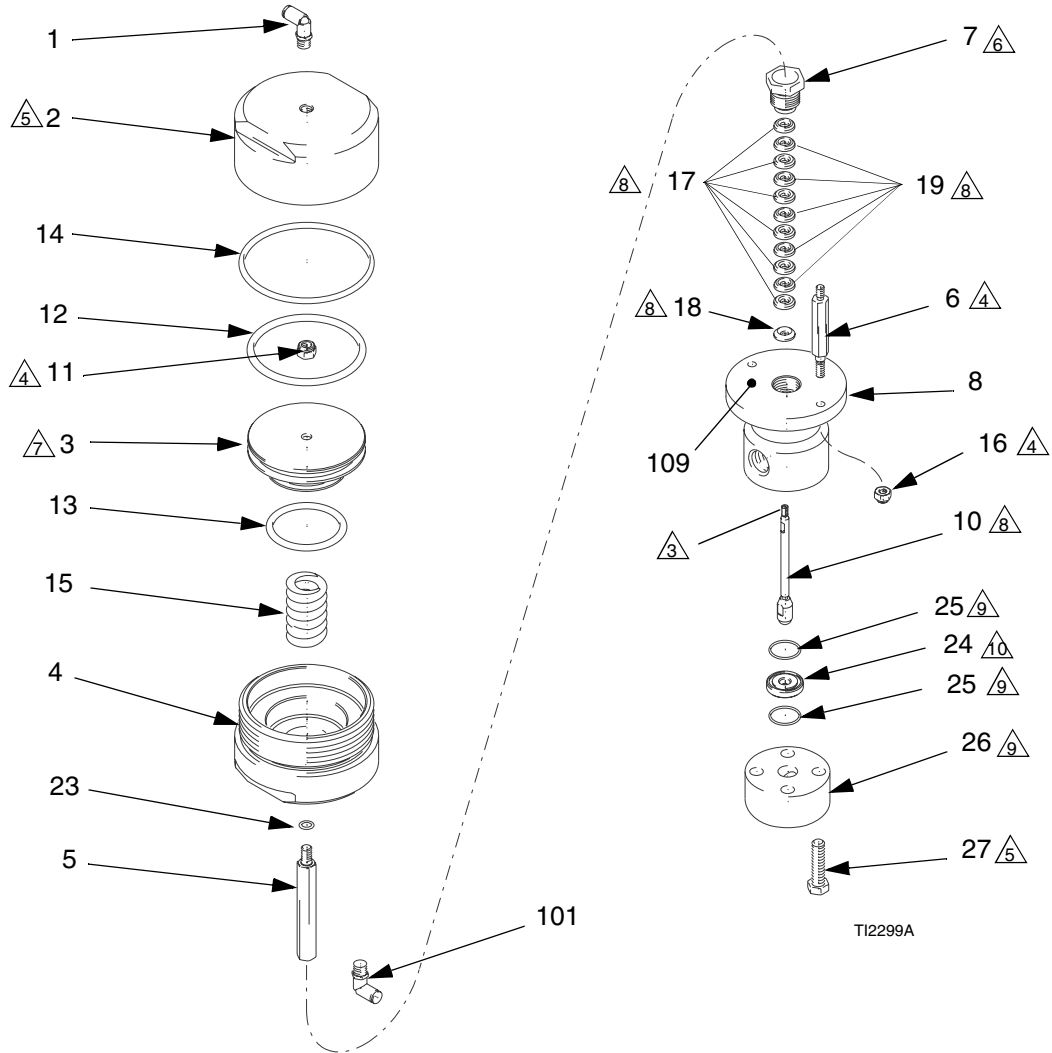

TI2299A

- 1. Apply pipe sealant to non-swiveling pipe threads.
- 2. Apply lubricant to threads, o-rings, and seals.
- 3. Apply blue thread lock. Thread to bottom.
- 4. Torque to 5-7 ft-lbs (7-9 N•m).
- 5. Torque to 30-40 ft-lbs (41-54 N•m).
- 6. Tighten packing nut 1/4 turn after nut bottoms out; 145-155 in./lbs (16-18 N•m). Check packing nut tightness about once a month. Keep packing nut filled with TSL.
- 7. Lubricate and press piston evenly into cylinder.

- 8. Clean needle (10) and packing cavity before reinstalling, packings (17, 18, 19). Lubricate packings and install with lips facing down away from packing nut (7) in order shown.
- 9. Replace o-rings (25) when seat housing (26) is removed.
- 10. Inspect reversible seat for damage. If one side is worn, reverse seat.

Common Parts

| Ref. | Part No. | Description | Qty. |
|------|----------|---------------------------------|------|
| 3 | 15A841 | PISTON, valve | 1 |
| 5 | 15B545 | ROD, piston | 1 |
| 6 | 15A834 | ROD, tie | 2 |
| 7 | 15A835 | NUT, packing | 1 |
| 9▲ | 15H108 | LABEL, pinch point | 1 |
| 10† | 245850 | STEM, needle and ball | 1 |
| 11 | 111040 | NUT, lock, insert, nylock, 5/16 | 1 |
| 12*† | 117336 | O-RING | 1 |
| 13*† | 117370 | O-RING | 1 |
| 14*† | 117337 | O-RING | 1 |
| 15† | 109141 | SPRING, compression | 1 |
| 16 | 102040 | NUT, lock, hex | 2 |
| 17*† | 117334 | PACKING, UHMWPE; blue | 6 |
| 18*† | 189901 | GLAND, male | 1 |
| 19*† | 117335 | PACKING, leather | 5 |
| 23*† | 111959 | O-RING | 1 |
| 24† | 15A830 | SEAT | 1 |
| 25*† | 15T260 | O-RING, solvent resist WHT | 2 |
| 27 | 102637 | SCREW, cap; 3-16 x 1/2 in. | 4 |

▲ Replacement Danger and Warning labels, tags, and cards are available at no cost.

* Parts included in Seal Kit 234098 (purchase separately).

† Parts included in Rebuild Kit 234131 (purchase separately).

Repair kits 234098 and 234131 work for either 255478 or 245846 dosing valves.

Varying Parts

| Ref. | Description | Dosing Valve | | Qty. |
|------|---------------------------------|--------------|--------|------|
| | | 255478 | 245846 | |
| 1 | FITTING, tube, elbow | 112781 | 598140 | 2 |
| 2 | CAP, valve | 15R975 | 15A840 | 1 |
| 4 | CYLINDER, valve | 15R974 | 15A840 | 1 |
| 8 | HOUSING, outlet | 15R973 | 15A833 | 1 |
| 26 | HOUSING, seat | 15M936 | 15A832 | 1 |
| 29✿ | PLUGE, pipe; 3/8 npt | 198292 | N/A | 1 |
| 30 | TAG, instruction | 15B678 | N/A | 1 |
| 31 | PLUG, port, pressure transducer | 198241 | N/A | 1 |
| 32 | O-RING, solvent resistant | 121399 | N/A | 1 |
| 33✿ | PLUG, pipe; 1/2 npt | 100361 | N/A | 1 |
| 36 | O-RING, PTFE | 121139 | N/A | 1 |

✿ Optional. Use if your valve doesn't use recirculation valves, sample valves, or thermo-wells.

✘ Series A valves used the 598140 5/32 OD fitting. Series B valves use the 112781 1/4 in. OD fitting.

Technical Data

| | |
|--------------------------------|---|
| Valve function | Normally open by spring; air to close; air assist to open |
| Maximum fluid working pressure | 7250 psi (50 MPa, 500 bar) |
| Maximum air working pressure | 100 psi (0.7 MPa, 7 bar) |
| Minimum air working pressure | 60 psi (0.4 MPa, 4 bar) |
| Maximum fluid temperature | 160°F (71°C) |
| Inlets | 1/2 npt (f) |
| Outlets | 255478: 1/2 npt (m) 245846: 3/8 npt (f) |
| Wetted parts | carbon steel, zinc plating, carbide, polyethylene, leather; fluid housings on 255478 are electroless nickel plated |

Dimensions

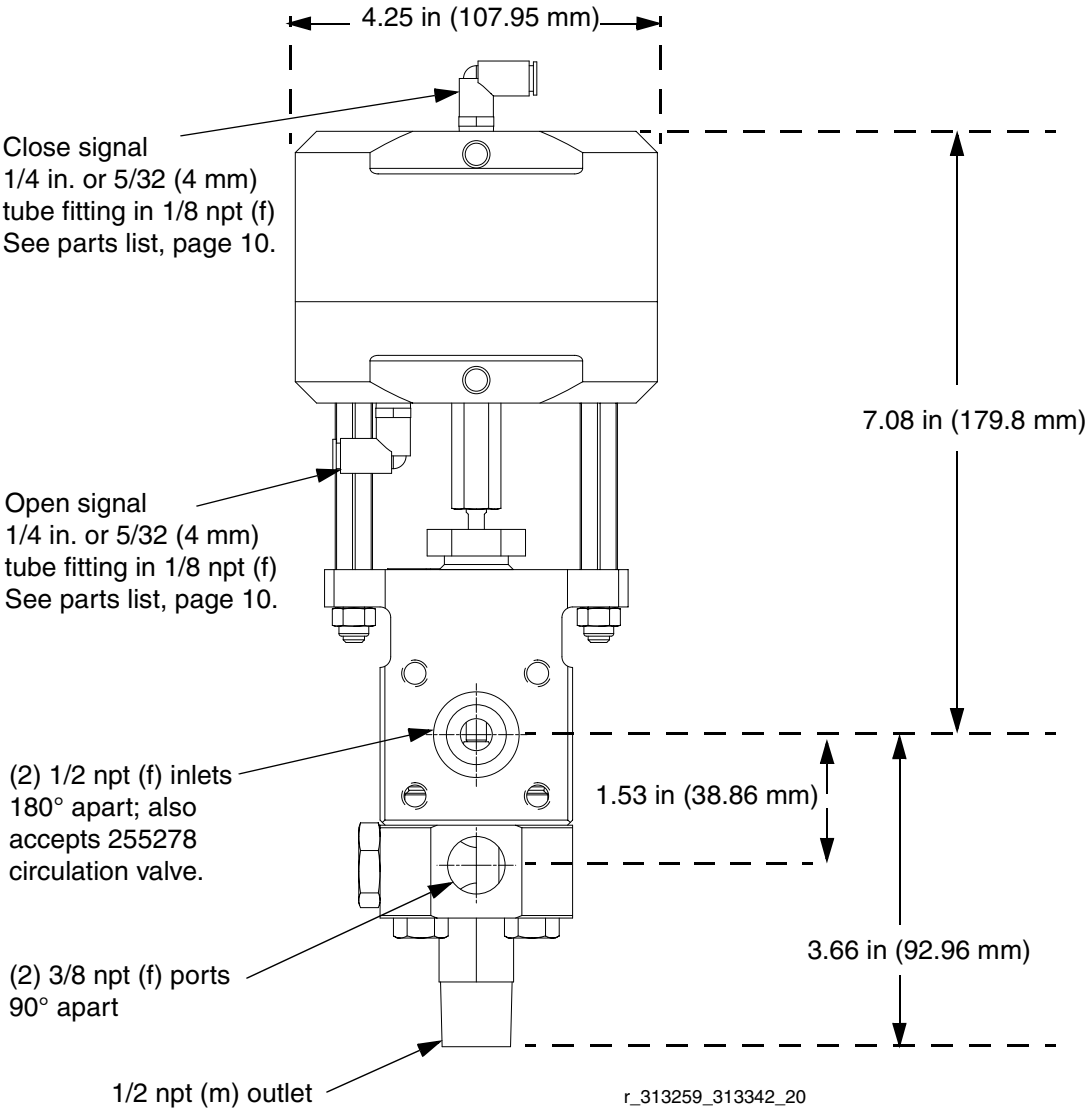

Graco Standard Warranty

Graco warrants all equipment referenced in this document which is manufactured by Graco and bearing its name to be free from defects in material and workmanship on the date of sale to the original purchaser for use. With the exception of any special, extended, or limited warranty published by Graco, Graco will, for a period of twelve months from the date of sale, repair or replace any part of the equipment determined by Graco to be defective. This warranty applies only when the equipment is installed, operated and maintained in accordance with Graco's written recommendations.

This warranty does not cover, and Graco shall not be liable for general wear and tear, or any malfunction, damage or wear caused by faulty installation, misapplication, abrasion, corrosion, inadequate or improper maintenance, negligence, accident, tampering, or substitution of non-Graco component parts. Nor shall Graco be liable for malfunction, damage or wear caused by the incompatibility of Graco equipment with structures, accessories, equipment or materials not supplied by Graco, or the improper design, manufacture, installation, operation or maintenance of structures, accessories, equipment or materials not supplied by Graco.

This warranty is conditioned upon the prepaid return of the equipment claimed to be defective to an authorized Graco distributor for verification of the claimed defect. If the claimed defect is verified, Graco will repair or replace free of charge any defective parts. The equipment will be returned to the original purchaser transportation prepaid. If inspection of the equipment does not disclose any defect in material or workmanship, repairs will be made at a reasonable charge, which charges may include the costs of parts, labor, and transportation.

THIS WARRANTY IS EXCLUSIVE, AND IS IN LIEU OF ANY OTHER WARRANTIES, EXPRESS OR IMPLIED, INCLUDING BUT NOT LIMITED TO WARRANTY OF MERCHANTABILITY OR WARRANTY OF FITNESS FOR A PARTICULAR PURPOSE.

Graco's sole obligation and buyer's sole remedy for any breach of warranty shall be as set forth above. The buyer agrees that no other remedy (including, but not limited to, incidental or consequential damages for lost profits, lost sales, injury to person or property, or any other incidental or consequential loss) shall be available. Any action for breach of warranty must be brought within two (2) years of the date of sale.

GRACO MAKES NO WARRANTY, AND DISCLAIMS ALL IMPLIED WARRANTIES OF MERCHANTABILITY AND FITNESS FOR A PARTICULAR PURPOSE, IN CONNECTION WITH ACCESSORIES, EQUIPMENT, MATERIALS OR COMPONENTS SOLD BUT NOT MANUFACTURED BY GRACO. These items sold, but not manufactured by Graco (such as electric motors, switches, hose, etc.), are subject to the warranty, if any, of their manufacturer. Graco will provide purchaser with reasonable assistance in making any claim for breach of these warranties.

In no event will Graco be liable for indirect, incidental, special or consequential damages resulting from Graco supplying equipment hereunder, or the furnishing, performance, or use of any products or other goods sold hereto, whether due to a breach of contract, breach of warranty, the negligence of Graco, or otherwise.

FOR GRACO CANADA CUSTOMERS

The Parties acknowledge that they have required that the present document, as well as all documents, notices and legal proceedings entered into, given or instituted pursuant hereto or relating directly or indirectly hereto, be drawn up in English. Les parties reconnaissent avoir convenu que la rédaction du présente document sera en Anglais, ainsi que tous documents, avis et procédures judiciaires exécutés, donnés ou intentés, à la suite de ou en rapport, directement ou indirectement, avec les procédures concernées.

Graco Information

For the latest information about Graco products, visit www.graco.com.

TO PLACE AN ORDER, contact your Graco distributor or call to identify the nearest distributor.

Phone: 612-623-6921 **or Toll Free:** 1-800-328-0211 **Fax:** 612-378-3505

*All written and visual data contained in this document reflects the latest product information available at the time of publication.
Graco reserves the right to make changes at any time without notice.*

Original instructions. This manual contains English. MM 313342

Graco Headquarters: Minneapolis

International Offices: Belgium, China, Japan, Korea

GRACO INC. AND SUBSIDIARIES • P.O. BOX 1441 • MINNEAPOLIS MN 55440-1441 • USA
Copyright 2009, Graco Inc. All Graco manufacturing locations are registered to ISO 9001.

www.graco.com
Revised 01/2012